



WK - Serie

Magnetschnäpper

INHALTSVERZEICHNIS ZUBEHÖR SCHLÖSSER

Magnetschnäpper

[V1.1]

Artikel	Seite	Artikel	Seite	Artikel	Seite	Artikel	Seite
2012	186-1						
2012/25N	186-2						
2013	186-3						
2014	186-4						
2015	186-5						

WK-Serie

2012

32.2012.NBK.0040

Artikelgruppe:	Magnetschnäpper
Bezeichnung:	Magnet Typ 2012 - Magnetverschlüsse zum Aufschrauben, Haftkraft 40 N
Artikel-Nr.:	32.2012.NBK.0040
Kessler-Nr.:	2012
Hersteller:	HUWIL HMT
Material:	Metallguss
Oberfläche:	vernickelt
Haftkraft:	40 N
	zum Aufschrauben
Zubehör:	Schließblech

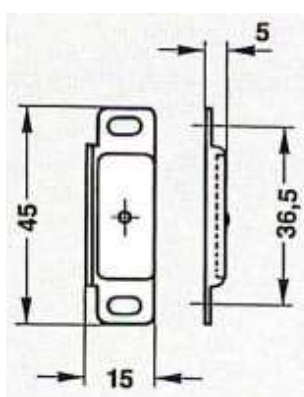
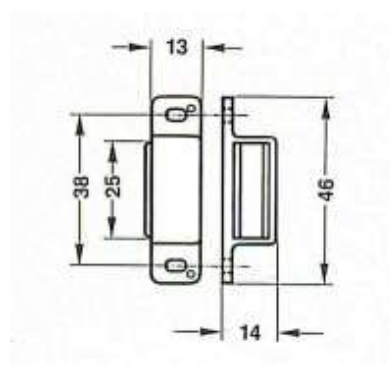

WK-Serie

2013

32.2013.NBK.0060

Artikelgruppe:	Magnetschnäpper
Bezeichnung:	Magnet Typ 2013 - Magnetverschlüsse zum Aufschrauben, Haftkraft 60 N
Artikel-Nr.:	32.2013.NBK.0060
Kessler-Nr.:	2013
Hersteller:	HUWIL HMT
Material:	Metallguss
Oberfläche:	vernickelt
Haftkraft:	60 N
	zum Aufschrauben
Zubehör:	Schließblech

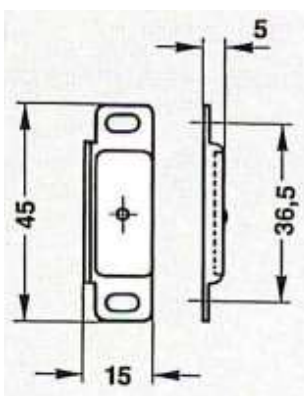
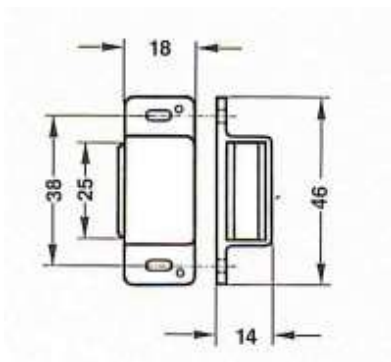

WK-Serie
2014
32.2014.NBK.0080

Artikelgruppe:	Magnetschnäpper
Bezeichnung:	Magnet Typ 2014 - Magnetverschlüsse zum Aufschrauben, Haftkraft 80 N
Artikel-Nr.:	32.2014.NBK.0080
Kessler-Nr.:	2014
Hersteller:	HUWIL HMT
Material:	Metallguss
Oberfläche:	vernickelt
Haftkraft:	80 N
	zum Aufschrauben
Zubehör:	Schließblech

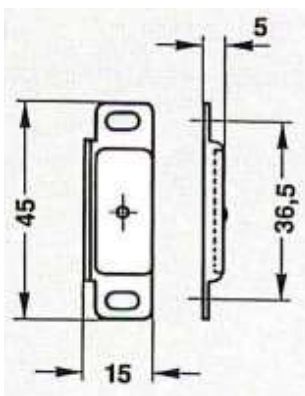
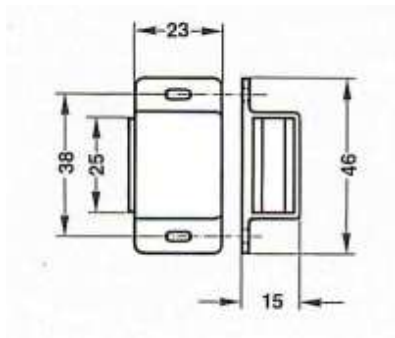

WK-Serie
2015
32.2015.NBK.0110

Artikelgruppe:	Magnetschnäpper
Bezeichnung:	Magnet Typ 2015 - Magnetverschlüsse zum Aufschrauben, Haftkraft 110 N
Artikel-Nr.:	32.2015.NBK.0110
Kessler-Nr.:	2015
Hersteller:	HUWIL HMT
Material:	Metallguss
Oberfläche:	vernickelt
Haftkraft:	110 N
	zum Aufschrauben
Zubehör:	Schließblech

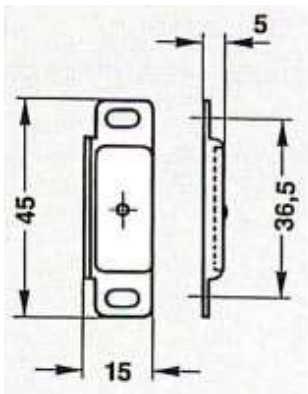
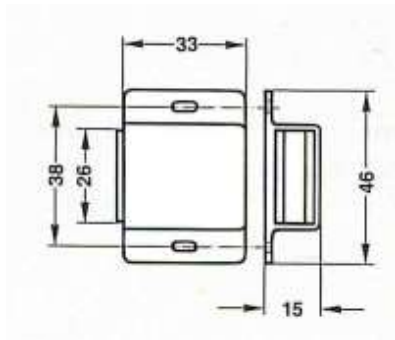

WK-Serie
2012/25 N
32.2012.NBK.0025

Artikelgruppe:	Magnetschnäpper
Bezeichnung:	Magnet Typ 2012 - Magnetverschlüsse zum Aufschrauben, Haftkraft 25 N
Artikel-Nr.:	32.2012.NBK.0025
Kessler-Nr.:	2012/25N
Hersteller:	HUWIL HMT
Material:	Metallguss
Oberfläche:	vernickelt
Haftkraft:	25 N
	zum Aufschrauben
Zubehör:	Schließblech

